



AGENDA

1960 Elgin Street
Oroville, CA 95966
530-533-2000
www.loapud.com

Board of Directors
Special Meeting
June 20, 2024 – 2:00 PM

Materials related to an item on the open meeting agenda that are provided to the Board of Directors, including those provided to the Board after distribution of the agenda packet, are available on the District website.

During this difficult time, we invite you to join today's scheduled meeting via Zoom by using your phone or computer to attend this meeting. Please call our District office at **(530)533-2000** for assistance in participating in the teleconference.

Dial in: 1-669-900-9128
Meeting ID: 879 9137 4038
Passcode: 946288

To ensure that our meetings are as orderly as possible, and to enable public participation at the proper times during the meeting, we are asking that everyone take a moment to ensure your line stays muted until public comment is invited. When it comes time for public comment, we will leave enough time for participants to unmute and speak to the entire group and our Board. Because attendees cannot see each other's mute status, we will simply need to be patient as we wait in between comments, and do our best not to speak over each other. Please state your name for the record before sharing comments. We are committed to keeping the public engaged throughout this crisis and appreciate your help in making that happen.

1. **CALL TO ORDER**

- 1.1 Roll Call
- 1.2 Flag Salute
- 1.3 Moment of Silence
- 1.4 Public Comment

2. **SUPPLEMENTAL AGREEMENT FOR UNION PACIFIC RAILROAD AND THE DISTRICT**

The Board will review and consider executing the supplemental agreement with Union Pacific Railroad for the District to replace the existing 12" carrier pipe with new 20" HDPE carrier pipe.

DISCUSSION WITH POSSIBLE ACTION

3. **ADDENDUM TO DEVELOPMENT AGREEMENT FOR THE CONSTRUCTION OF THE A-LINE PIPELINE**

The Board will review and consider executing the addendum to the Development Agreement between the District and the Richman Group for the replacement and connection of the A-Line at Lincoln Street Affordable Housing Sewer System.

DISCUSSION WITH POSSIBLE ACTION

4. **APPOINT SC-OR COMISSIONERS FOR 2024-2025**

The President will name two (2) Directors to sit on the SC-OR Commission for 2024-2025 and designate a voting representative.

DISCUSSION WITH POSSIBLE ACTION

ADJOURNMENT



Manager's Report

To: Board of Directors
From: David Goyer, General Manager
Date: June 20, 2024

RE: Item #1 – CALL TO ORDER

1.1 Roll call

1.2 Flag Salute

1.3 Moment of Silence

1.4 Public Comment



Manager's Report

To: Board of Directors

From: David Goyer, General Manager

Date: June 20, 2024

RE: Item #2 – Supplemental Agreement with Union Pacific Railroad and the District

The Board will review and consider executing the Supplemental Agreement with Union Pacific Railroad and the District to replace the existing 12" carrier pipe with new 20" HDPE carrier pipe.

Attachments for each item included.

Recommended Action:

A motion to approve and execute the Supplemental Agreement with Union Pacific Railroad and the District.

Roll call vote.



June 7, 2024
Project: 0627851

LAKE OROVILLE AREA PUBLIC UTILITY DISTRICT

RE: Supplemental Agreement for License Audit No. WP8515, Covering Use of Railroad Property at Mile Post 203.75 on the Sacramento Subdivision at or near Oroville, Butte County, California

Attached is an original of the agreement covering your use of the Railroad Company's right of way. Please return the executed agreement via email. For any payment(s), please follow the accompanying instructions.

An original copy of the fully-executed document will be returned to you, when approved and processed by the Railroad Company.

Payment in the amount of Three Thousand Five Hundred Dollars (**\$3,500.00**) is due and payable to Union Pacific Railroad Company upon your execution of the agreement. Please include your payment, **with Project No. 0627851 noted on that document.** If you require formal billing, you may consider this letter as a formal bill.

In compliance with the Internal Revenue Service's policy regarding Form 1099, I certify that 946001323 is the Railroad Company's correct Federal Taxpayer Identification Number and that Union Pacific Railroad Company is doing business as a corporation.

Sincerely,

A handwritten signature in blue ink that reads "Kris Jones".

Kris Jones
Senior Analyst Real Estate - Contracts

SUPPLEMENTAL AGREEMENT

THIS SUPPLEMENTAL AGREEMENT is entered into on _____, 2024, between **UNION PACIFIC RAILROAD COMPANY** (“Licensor”) and **LAKE OROVILLE AREA PUBLIC UTILITY DISTRICT**, California Municipal Corporation, whose address is 1960 Elgin Street, Oroville, California 95966 (“Licensee”).

RECITALS:

By instrument dated May 15, 1951, Licensor and Licensee, or their predecessors in interest, entered into an agreement (“Basic Agreement”), identified as Audit No. WP8515, at Oroville, California.

AGREEMENT:

NOW, THEREFORE, IT IS AGREED by and between the parties hereto as follows:

Article 1. SUBSTITUTION OF PRINT.

The print dated May 28, 2024, attached hereto as Exhibit 'A', shall be and hereby is substituted for the print dated April 18, 1951, attached to the Basic Agreement, and from and after the effective date herein whenever the term is used in the Basic Agreement, or any amendment or supplement thereto (if any), such reference shall be deemed to refer to the Exhibit 'A', hereto attached.

Article 2. CONSENT TO WORK.

This Supplemental Agreement will serve as notification that the Railroad Company approves of your intentions to replace the existing twelve inch (12") carrier pipe with a new twenty inch (20") HDPE carrier pipe in the existing thirty inch (30") steel casing in accordance with Exhibit A.

Article 3. CONTRACTOR RIGHT OF ENTRY.

If a contractor is to do any of the work performed on or about the Railroad Company’s property, then Licensee shall require its contractor to execute the Railroad Company’s form Contractor's Right of Entry Agreement, EXHIBIT B. Licensee acknowledges receipt of a copy of Contractor's Right of Entry Agreement and understanding its term, provisions and requirements, and will inform its contractor of the need to execute the Agreement. Under no circumstances will Licensee’s contractor be allowed on or about the Railroad Company’s property without first executing the Contractor's Right of Entry Agreement.

Article 4. NOTICE OF COMMENCEMENT OF WORK / RAILROAD REPRESENTATIVE / SUPERVISION / FLAGGING / SAFETY.

If an emergency should arise requiring immediate attention, the Licensee shall provide as much notice as practicable to Railroad, by calling the Response Management Communication Center at (888) 877-7267 before commencing any work. In all other situations, the Licensee shall notify the Railroad at least ten (10) days (or such other time as the Railroad may allow) in advance of the commencement of any work upon property of the Railroad in connection with the construction, maintenance, repair,

renewal, modification, reconstruction, relocation or removal of the Crossing - Pipeline. All such work shall be prosecuted diligently to completion. The Licensee will coordinate its initial and any subsequent work with a Railroad approved flagger provided at the link below and the following employee of Railroad or his or her duly authorized representative (hereinafter "Railroad Representative" or "Railroad Representative"):

<p>http://www.up.com/flagging</p>	<p>Jeff S. Stewart Manager I Signal Maintenance Phone: 408-442-4129 Email: jsstewar@up.com</p>
--	--

Article 5. EFFECTIVE DATE.

This Supplemental Agreement shall be effective as of _____, 2024.

Article 6. AGREEMENT SUPPLEMENT.

Nothing in this Supplemental Agreement shall be construed as amending or modifying the Basic Agreement unless specifically provided herein.

Article 7. ADMINSTRATIVE HANDLING CHARGE.

Upon execution of this Supplemental Agreement, Licensee shall pay to Licensor an Administrative Handling Charge of Three Thousand Five Hundred Dollars (\$3,500.00).

Article 8. DUTY TO NOTIFY LESSEE PRIOR TO COMMENCEMENT OF ANY WORK

This Agreement affects an industrial lease as between the Railroad, Lessor, and SHIFFLET BROTHERS ENTERPRISES, INC., Lessee. Licensee shall notify the lessee in writing at least ten (10) days in advance of the commencement of any work on Licensor's property, in arising out of or related to the construction, maintenance, repair, renewal, modification, reconstruction, relocation, and/or removal of the pipeline crossing, which is listed below:

Lessee: EVA PRICE
SHIFFLET BROTHERS ENTERPRISES, INC.
2593 S FIFTH AVENUE
OROVILLE, CALIFORNIA 95965
530-533-8806 / 530-701-4897

Licensee is liable for any and all storage property damage that Lessee's property suffers arising out of or related to the construction, maintenance, repair, renewal, modification, reconstruction, relocation, and/or removal of the pipeline crossing.

Article 9. SPECIAL PROVISION – CONSTRUCTION OBSERVATION.

Licensors requires Licensee to provide monitoring of tracks and construction observation through Licensor approved observer named below during all construction and installation work. Licensee is to directly coordinate services with the named inspector:

Railpros Field Services
Email: RP.Utility@railpros.com
Phone (682)223-5271

IN WITNESS WHEREOF, the parties have executed this Supplemental Agreement as of the day and year first written.

UNION PACIFIC RAILROAD COMPANY

LAKE OROVILLE AREA PUBLIC UTILITY DISTRICT

By: _____

By: _____

Kris Jones
Senior Analyst Real Estate - Contracts

Name Printed: _____

Title: _____

NON-FLAMMABLE LIQUID PIPELINE

- CROSSING
- ENCROACHMENT
- BOTH

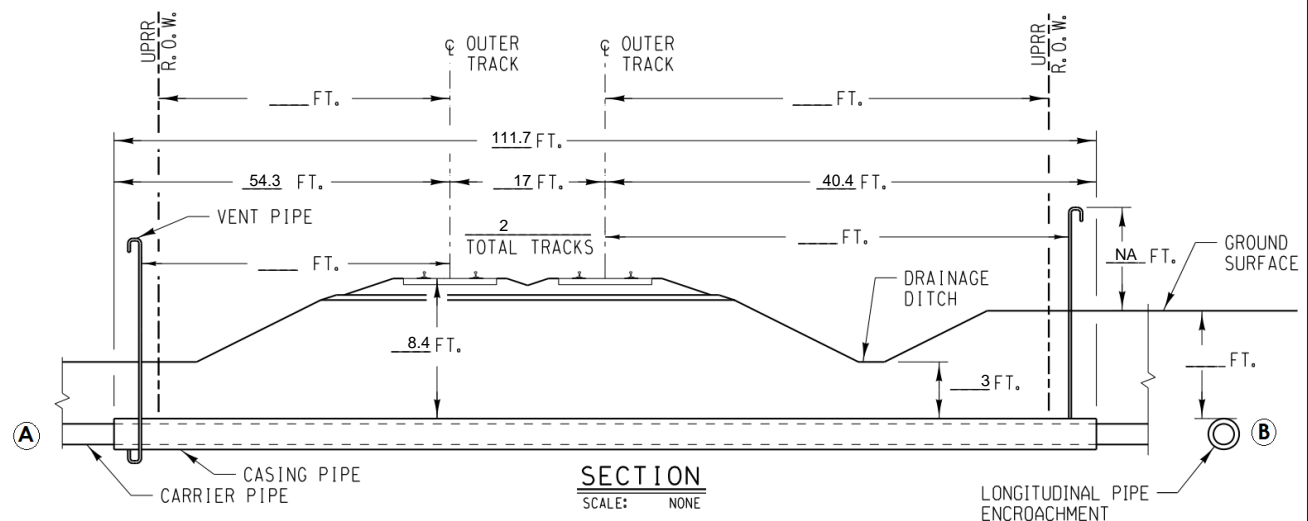
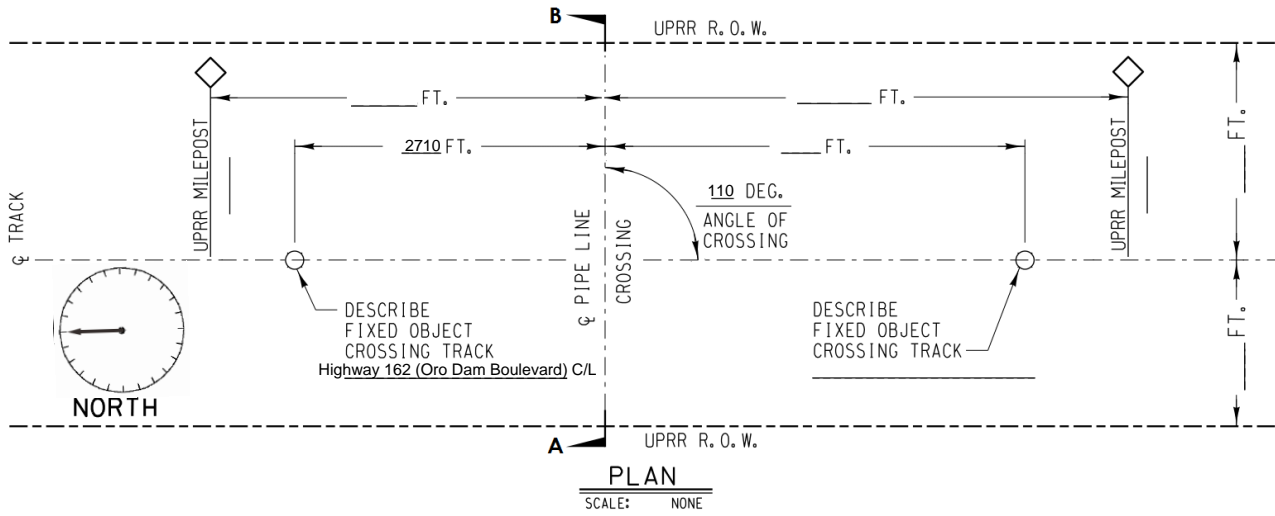

- NOTES:
 1) ALL DIMENSIONS MEASURED PERPENDICULAR TO THE CENTERLINE OF TRACK
 2) REFER TO AREMA VOLUME 1. CHAPTER 1. PART 5. SECTION 5.1

- A) METHOD OF INSTALLATION SLIPLINE NEW CARRIER INTO EXISTING CASING
 B) DIST. FROM CENTERLINE OF TRACK TO PIPE ENCROACHMENT _____
 C) SIGNS PROVIDED? AT MINIMUM SIGNS WILL BE PROVIDED AS STATED ABOVE
 D) CARRIER MATERIAL HDPE. IF RCP, CLASS V? NA.
 COMMODITY TO BE CONVEYED SEWER.
 OPERATIONAL PRESSURE 0 PSI. MAOP 80 PSI.
 WALL THICKNESS (INCH)/ SCHEDULE 0.83"/DR 26. DIAMETER 20 IN.
 CATHODIC/COATING PROTECTION NO
 E) CASING MATERIAL STEEL PIPE (EXISTING). IF RCP, CLASS V? NA.
 TOTAL LENGTH CASING PIPE: 117.89 FT.
 WALL THICKNESS 0.5 IN. DIAMETER 30 IN.
 CATHODIC/COATING PROTECTION YES.
 CASING PIPE IS SEALED AT THE ENDS.
 F) DISTANCE FROM CENTERLINE OF TRACK TO NEAR FACE OF BORING AND JACKING PITS WHEN MEASURED AT RIGHT ANGLES
40 AND 54.



EXHIBIT "A"

SUBDIVISION:		
TRACK TYPE: MAINLINE TRACK		
M.P.:	LAT.: 39.49527778	
E.S.M.:	LONG.: -121.55555556	
NEAREST CITY:	COUNTY:	STATE:
OROVILLE	BUTTE	CA
APPLICANT: LAKE OROVILLE AREA PUBLIC UTILITY DISTRICT		
FILE NO.:	DATE:	
0793765	5/28/2024	

Project: 0627851

To the Contractor:

Before Union Pacific Railroad Company can permit you to perform work on its right of way, it will be necessary to return an original of the enclosed Contractor Right of Entry Agreement as follows:

1. Fill in the complete legal name of the contractor in the space provided on Page 1 of the Contractor's Right of Entry Agreement.
2. Fill in the name of the contractor in the space provided in the signature block at the end of the Contractor's Right of Entry Agreement. If the contractor is a corporation, the person signing on its behalf must be an elected corporate officer.
3. Please execute on your behalf and return the document via EMAIL.
4. Payment, **with Project No. 0627851 referenced**, to the Union Pacific Railroad Company in the amount of **One Thousand Dollars (\$1,000.00)**. If you require formal billing, you may consider this letter as a formal bill. In compliance with the Internal Revenue Service's new policy regarding their Form 1099, I certify that 946001323 is the Railroad Company's correct Federal Taxpayer Identification Number and that UNION PACIFIC RAILROAD COMPANY is doing business as a corporation.

Send Electronic Payments to:

- Name: Bank of America, Dallas, TX
- Union Pacific Account = 3752021457
 - ACH Routing Number = 1110-0001-2
 - Wire Routing Number = 026009593
- **Reference = Project Number 0627851**

Send Check to:

Union Pacific Railroad Company
12567 Collection Center Drive
Chicago, IL 60693

- **Reference = Project Number 0627851**
- **PARTIALLY EXECUTED AGREEMENTS SENT TO CHICAGO WILL NOT BE PROCESSED**

UP does not currently offer a credit card option.

After approval of the Right of Entry Agreement, one fully-executed counterpart of the Agreement will be returned to you via email. In no event should you begin work until you have received your counterpart of the fully-executed Agreement.

Sincerely,

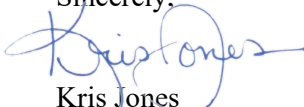

Kris Jones
Senior Analyst Real Estate - Contracts

EXHIBIT B
TO
SUPPLEMENTAL AGREEMENT

Project No. 0627851

Form Approved, AVP-Law
09/01/2018

CONTRACTOR'S RIGHT OF ENTRY AGREEMENT

THIS AGREEMENT is made and entered into as of the _____ by and between UNION PACIFIC RAILROAD COMPANY, a Delaware corporation, ("Railroad") and _____, a _____ corporation ("Contractor"), to be addressed at _____.

RECITALS:

The Contractor has been hired by **LAKE OROVILLE AREA PUBLIC UTILITY DISTRICT** to replace the existing twelve inch (12") carrier pipe with a new twenty inch (20") HDPE carrier pipe in the existing thirty inch (30") steel casing (the "work"), with all or a portion of such work to be performed on property of Railroad at Mile Post 203.75, on the Sacramento Subdivision at or near Oroville, Butte County, California pursuant to a Supplemental Agreement between Railroad and LAKE OROVILLE AREA PUBLIC UTILITY DISTRICT with an effective date of _____, 2024 at such location as shown on the print marked **Exhibit A** attached hereto and hereby made a part hereof.

Railroad is willing to permit Contractor to perform the work described above at the location described above subject to the terms and conditions contained in this Agreement.

AGREEMENT:

NOW, THEREFORE, it is mutually agreed by and between the Railroad and Contractor, as follows:

Article I. DEFINITION OF CONTRACTOR.

For purposes of this Agreement, all references in this Agreement to the Contractor shall include Contractor's contractors, subcontractors, officers, agents and employees, and others acting under its or their authority.

Article II. RIGHT GRANTED; PURPOSE.

Railroad hereby grants to Contractor the right, during the term hereinafter stated and upon and subject to each and all of the terms, provisions and conditions herein contained, to enter upon and have ingress to and egress from the property described in the Recitals for the purpose of performing any work described in the Recitals above. The right herein granted to Contractor is limited to those portions of Railroad's property specifically described herein, or as designated by the Railroad Representative named in Article IV, and is strictly limited to the scope of work identified to the Railroad, as determined by the Railroad in its sole discretion, and for no other purpose.

Article III. TERMS AND CONDITIONS CONTAINED IN EXHIBITS B AND C.

The terms and conditions contained in **Exhibit B** and **C**, attached hereto, are hereby made a part of this Agreement.

Article IV. ALL EXPENSES TO BE BORNE BY CONTRACTOR; RAILROAD REPRESENTATIVE.

A. Contractor shall bear any and all costs and expenses associated with any work performed by Contractor, or any costs or expenses incurred by Railroad relating to this Agreement.

B. Contractor shall coordinate all of its work with the following Railroad representative or his or her duly authorized representative (the "Railroad Representative"):

http://www.up.com/flagging	Jeff S. Stewart Manager I Signal Maintenance Phone: 408-442-4129 Email: jsstewar@up.com
---	--

C. Contractor, at its own expense, shall adequately police and supervise all work to be performed by Contractor and shall ensure that such work is performed in a safe manner as set forth in Section 7 of **Exhibit B**. The responsibility of Contractor for safe conduct and adequate policing and supervision of Contractor's work shall not be lessened or otherwise affected by Railroad's approval of plans and specifications involving the work, or by Railroad's collaboration in performance of any work, or by the presence at the work site of a Railroad Representative, or by compliance by Contractor with any requests or recommendations made by Railroad Representative.

Article V. TERM; TERMINATION.

A. The grant of right herein made to Contractor shall commence on the date of this Agreement, and continue for one (1) year, unless sooner terminated as herein provided, or at such time as Contractor has completed its work on Railroad's property, whichever is earlier. Contractor agrees to notify the Railroad Representative in writing when it has completed its work on Railroad's property.

B. This Agreement may be terminated by either party on ten (10) days written notice to the other party.

Article VI. CERTIFICATE OF INSURANCE.

A. Only upon request, Contractor will provide Railroad with the insurance binders, policies, certificates and/or endorsements set forth in **Exhibit C** of this Agreement.

B. All insurance correspondence, binders, policies, certificates and/or endorsements shall be sent to:

Union Pacific Railroad Company
Attn: Analyst – Real Estate Utilities (0627851)
1400 Douglas Street STOP 1690
Omaha, Nebraska 68179-1690

Article VII. CHOICE OF FORUM.

Litigation arising out of or connected with this Agreement may be instituted and maintained in the courts of the State of California only, and the parties consent to jurisdiction over their person and over the subject matter of any such litigation, in those courts, and consent to service of process issued by such courts.

Article VIII. DISMISSAL OF CONTRACTOR'S EMPLOYEE.

At the request of Railroad, Contractor shall remove from Railroad's property any employee of Contractor who fails to conform to the instructions of the Railroad Representative in connection with

the work on Railroad's property, and any right of Contractor shall be suspended until such removal has occurred. Contractor shall indemnify Railroad against any claims arising from the removal of any such employee from Railroad's property.

Article IX. ADMINISTRATIVE FEE.

Upon the execution and delivery of this Agreement, Contractor shall pay to Railroad **One Thousand Dollars (\$1,000.00)** as reimbursement for clerical, administrative and handling expenses in connection with the processing of this Agreement.

Article X. CROSSINGS.

No additional vehicular crossings (including temporary haul roads) or pedestrian crossings over Railroad's trackage shall be installed or used by Contractor without the prior written permission of Railroad.

Article XI. EXPLOSIVES.

Explosives or other highly flammable substances shall not be stored on Railroad's property without the prior written approval of Railroad.

IN WITNESS WHEREOF, the parties have caused this Agreement to be executed in duplicate as of the date first herein written.

UNION PACIFIC RAILROAD COMPANY

By: _____

Kris Jones
Senior Analyst Real Estate - Contracts

(Contractor Name)

By _____

Name: _____

Title: _____

Telephone: _____

Email: _____

NON-FLAMMABLE LIQUID PIPELINE

- CROSSING
- ENCROACHMENT
- BOTH

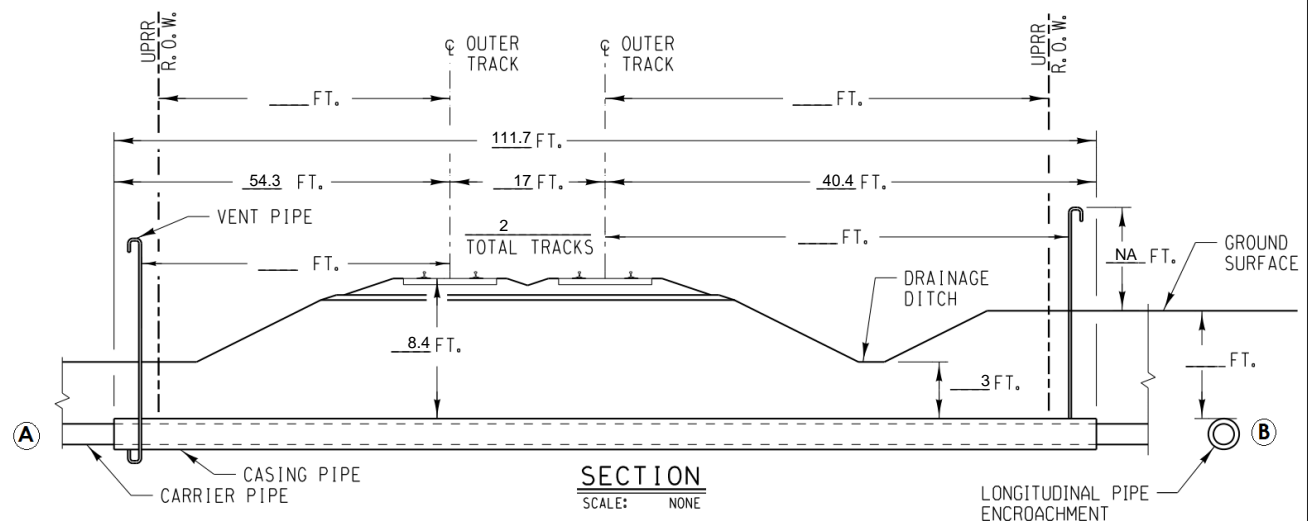
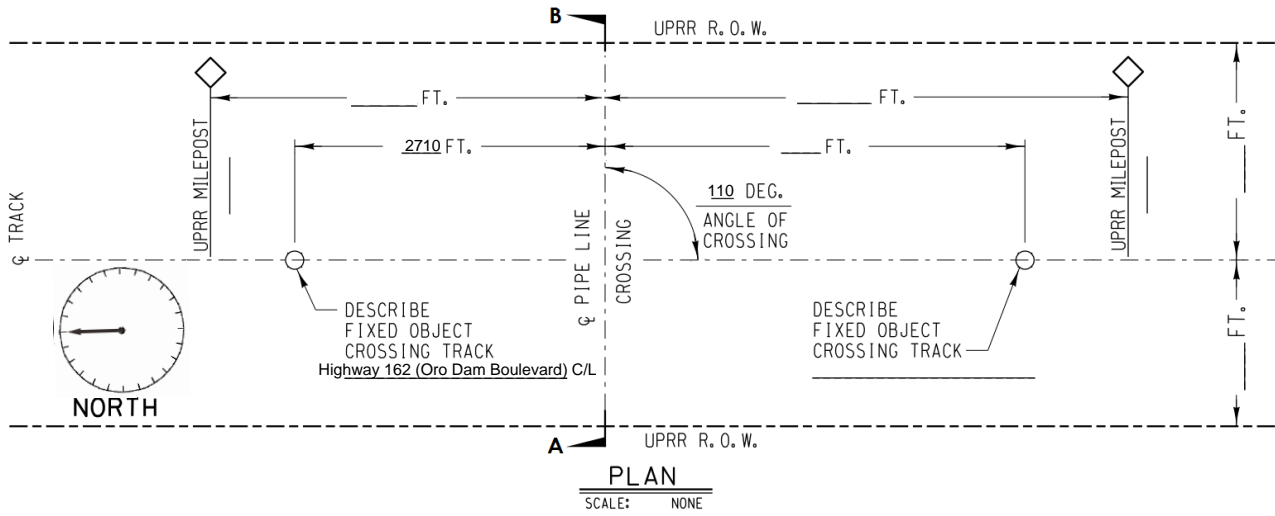

- NOTES:
 1) ALL DIMENSIONS MEASURED PERPENDICULAR TO THE CENTERLINE OF TRACK
 2) REFER TO AREMA VOLUME 1. CHAPTER 1. PART 5. SECTION 5.1

- A) METHOD OF INSTALLATION SLIPLINE NEW CARRIER INTO EXISTING CASING
 B) DIST. FROM CENTERLINE OF TRACK TO PIPE ENCROACHMENT _____
 C) SIGNS PROVIDED? AT MINIMUM SIGNS WILL BE PROVIDED AS STATED ABOVE
 D) CARRIER MATERIAL HDPE. IF RCP, CLASS V? NA.
 COMMODITY TO BE CONVEYED SEWER.
 OPERATIONAL PRESSURE 0 PSI. MAOP 80 PSI.
 WALL THICKNESS (INCH)/ SCHEDULE 0.83"/DR 26. DIAMETER 20 IN.
 CATHODIC/COATING PROTECTION NO
 E) CASING MATERIAL STEEL PIPE (EXISTING). IF RCP, CLASS V? NA.
 TOTAL LENGTH CASING PIPE: 117.89 FT.
 WALL THICKNESS 0.5 IN. DIAMETER 30 IN.
 CATHODIC/COATING PROTECTION YES.
 CASING PIPE IS SEALED AT THE ENDS.
 F) DISTANCE FROM CENTERLINE OF TRACK TO NEAR FACE OF BORING AND JACKING PITS WHEN MEASURED AT RIGHT ANGLES
40 AND 54.



EXHIBIT "A"

SUBDIVISION:		
TRACK TYPE: MAINLINE TRACK		
M.P.:	LAT.: 39.49527778	
E.S.M.:	LONG.: -121.55555556	
NEAREST CITY:	COUNTY:	STATE:
OROVILLE	BUTTE	CA
APPLICANT: LAKE OROVILLE AREA PUBLIC UTILITY DISTRICT		
FILE NO.:	0793765	DATE: 5/28/2024

EXHIBIT B
To
CONTRACTOR'S RIGHT OF ENTRY AGREEMENT

Section 1. NOTICE OF COMMENCEMENT OF WORK - FLAGGING.

A. Contractor agrees to notify the Railroad Representative at least ten (10) working days in advance of Contractor commencing its work and at least ten (10) working days in advance of proposed performance of any work by Contractor in which any person or equipment will be within twenty-five (25) feet of any track, or will be near enough to any track that any equipment extension (such as, but not limited to, a crane boom) will reach to within twenty-five (25) feet of any track. No work of any kind shall be performed, and no person, equipment, machinery, tool(s), material(s), vehicle(s), or thing(s) shall be located, operated, placed, or stored within twenty-five (25) feet of any of Railroad's track(s) at any time, for any reason, unless and until a Railroad flagman is provided to watch for trains. Upon receipt of such ten (10)-day notice, the Railroad Representative will determine and inform Contractor whether a flagman need be present and whether Contractor needs to implement any special protective or safety measures. If flagging or other special protective or safety measures are performed by Railroad, Railroad will bill Contractor for such expenses incurred by Railroad, unless Railroad and a federal, state or local governmental entity have agreed that Railroad is to bill such expenses to the federal, state or local governmental entity. If Railroad will be sending the bills to Contractor, Contractor shall pay such bills within thirty (30) days of Contractor's receipt of billing. If Railroad performs any flagging, or other special protective or safety measures are performed by Railroad, Contractor agrees that Contractor is not relieved of any of its responsibilities or liabilities set forth in this Agreement.

B. The rate of pay per hour for each flagman will be the prevailing hourly rate in effect for an eight-hour day for the class of flagmen used during regularly assigned hours and overtime in accordance with Labor Agreements and Schedules in effect at the time the work is performed. In addition to the cost of such labor, a composite charge for vacation, holiday, health and welfare, supplemental sickness, Railroad Retirement and unemployment compensation, supplemental pension, Employees Liability and Property Damage and Administration will be included, computed on actual payroll. The composite charge will be the prevailing composite charge in effect at the time the work is performed. One and one-half times the current hourly rate is paid for overtime, Saturdays and Sundays, and two and one-half times current hourly rate for holidays. Wage rates are subject to change, at any time, by law or by agreement between Railroad and its employees, and may be retroactive as a result of negotiations or a ruling of an authorized governmental agency. Additional charges on labor are also subject to change. If the wage rate or additional charges are changed, Contractor (or the governmental entity, as applicable) shall pay on the basis of the new rates and charges.

C. Reimbursement to Railroad will be required covering the full eight-hour day during which any flagman is furnished, unless the flagman can be assigned to other Railroad work during a portion of such day, in which event reimbursement will not be required for the portion of the day during which the flagman is engaged in other Railroad work. Reimbursement will also be required for any day not actually worked by the flagman following the flagman's assignment to work on the project for which Railroad is required to pay the flagman and which could not reasonably be avoided by Railroad by assignment of such flagman to other work, even though Contractor may not be working during such time. When it becomes necessary for Railroad to bulletin and assign an employee to a flagging position in compliance with union collective bargaining agreements, Contractor must provide Railroad a minimum of five (5) days notice prior to the cessation of the need for a flagman. If five (5) days notice of cessation is not given, Contractor will still be required to pay flagging charges for the five (5) day notice period required by union agreement to be given to the employee, even though flagging is not

required for that period. An additional ten (10) days notice must then be given to Railroad if flagging services are needed again after such five day cessation notice has been given to Railroad.

Section 2. LIMITATION AND SUBORDINATION OF RIGHTS GRANTED

A. The foregoing grant of right is subject and subordinate to the prior and continuing right and obligation of the Railroad to use and maintain its entire property including the right and power of Railroad to construct, maintain, repair, renew, use, operate, change, modify or relocate railroad tracks, roadways, signal, communication, fiber optics, or other wirelines, pipelines and other facilities upon, along or across any or all parts of its property, all or any of which may be freely done at any time or times by Railroad without liability to Contractor or to any other party for compensation or damages.

B. The foregoing grant is also subject to all outstanding superior rights (including those in favor of licensees and lessees of Railroad's property, and others) and the right of Railroad to renew and extend the same, and is made without covenant of title or for quiet enjoyment.

Section 3. NO INTERFERENCE WITH OPERATIONS OF RAILROAD AND ITS TENANTS.

A. Contractor shall conduct its operations so as not to interfere with the continuous and uninterrupted use and operation of the railroad tracks and property of Railroad, including without limitation, the operations of Railroad's lessees, licensees or others, unless specifically authorized in advance by the Railroad Representative. Nothing shall be done or permitted to be done by Contractor at any time that would in any manner impair the safety of such operations. When not in use, Contractor's machinery and materials shall be kept at least fifty (50) feet from the centerline of Railroad's nearest track, and there shall be no vehicular crossings of Railroads tracks except at existing open public crossings.

B. Operations of Railroad and work performed by Railroad personnel and delays in the work to be performed by Contractor caused by such railroad operations and work are expected by Contractor, and Contractor agrees that Railroad shall have no liability to Contractor, or any other person or entity for any such delays. The Contractor shall coordinate its activities with those of Railroad and third parties so as to avoid interference with railroad operations. The safe operation of Railroad train movements and other activities by Railroad takes precedence over any work to be performed by Contractor.

Section 4. LIENS.

Contractor shall pay in full all persons who perform labor or provide materials for the work to be performed by Contractor. Contractor shall not create, permit or suffer any mechanic's or materialmen's liens of any kind or nature to be created or enforced against any property of Railroad for any such work performed. Contractor shall indemnify and hold harmless Railroad from and against any and all liens, claims, demands, costs or expenses of whatsoever nature in any way connected with or growing out of such work done, labor performed, or materials furnished. If Contractor fails to promptly cause any lien to be released of record, Railroad may, at its election, discharge the lien or claim of lien at Contractor's expense.

Section 5. PROTECTION OF FIBER OPTIC CABLE SYSTEMS.

A. Fiber optic cable systems may be buried on Railroad's property. Protection of the fiber optic cable systems is of extreme importance since any break could disrupt service to users resulting in business interruption and loss of revenue and profits. Contractor shall visit up.com/CBUD to complete and submit the required form to determine if fiber optic cable is buried anywhere on Railroad's property to be used by Contractor. If it is, Contractor will telephone the telecommunications company(ies) involved, make arrangements for a cable locator and, if applicable, for relocation or other protection of the fiber optic cable. Contractor shall not commence any work until all such protection or relocation (if applicable) has been accomplished.

B. In addition to other indemnity provisions in this Agreement, Contractor shall indemnify, defend and hold Railroad harmless from and against all costs, liability and expense whatsoever (including, without limitation, attorneys' fees, court costs and expenses) arising out of any act or omission of Contractor, its agents and/or employees, that causes or contributes to (1) any damage to or destruction of any telecommunications system on Railroad's property, and/or (2) any injury to or death of any person employed by or on behalf of any telecommunications company, and/or its contractor, agents and/or employees, on Railroad's property. Contractor shall not have or seek recourse against Railroad for any claim or cause of action for alleged loss of profits or revenue or loss of service or other consequential damage to a telecommunication company using Railroad's property or a customer or user of services of the fiber optic cable on Railroad's property.

Section 6. PERMITS - COMPLIANCE WITH LAWS.

In the prosecution of the work covered by this Agreement, Contractor shall secure any and all necessary permits and shall comply with all applicable federal, state and local laws, regulations and enactments affecting the work including, without limitation, all applicable Federal Railroad Administration regulations.

Section 7. SAFETY.

A. Safety of personnel, property, rail operations and the public is of paramount importance in the prosecution of the work performed by Licensee or its contractor. Licensee shall be responsible for initiating, maintaining and supervising all safety, operations and programs in connection with the work. Licensee and its contractor shall at a minimum comply with Licensor's then current safety standards located at www.up.com/cs/groups/public/@uprr/@suppliers/documents/up_pdf_nativedocs/pdf_up_supplier_safety_req.pdf to ensure uniformity with the safety standards followed by Licensor's own forces. As a part of Licensee's safety responsibilities, Licensee shall notify Licensor if it determines that any of Licensor's safety standards are contrary to good safety practices. Licensee and its contractor shall furnish copies of each of its employees before they enter the job site.

B. Without limitation of the provisions of paragraph A above, Contractor shall keep the job site free from safety and health hazards and ensure that its employees are competent and adequately trained in all safety and health aspects of the job.

C. Contractor shall have proper first aid supplies available on the job site so that prompt first aid services may be provided to any person injured on the job site. Contractor shall promptly notify Railroad of any U.S. Occupational Safety and Health Administration reportable injuries. Contractor shall have a nondelegable duty to control its employees while they are on the job site or any other property of Railroad, and to be certain they do not use, be under the influence of, or have in their possession any alcoholic beverage, drug or other substance that may inhibit the safe performance of any work.

D. If and when requested by Railroad, Contractor shall deliver to Railroad a copy of Contractor's safety plan for conducting the work (the "Safety Plan"). Railroad shall have the right, but

not the obligation, to require Contractor to correct any deficiencies in the Safety Plan. The terms of this Agreement shall control if there are any inconsistencies between this Agreement and the Safety Plan.

Section 8. INDEMNITY.

A. To the extent not prohibited by applicable statute, Contractor shall indemnify, defend and hold harmless Railroad, its affiliates, and its and their officers, agents and employees ("Indemnified Parties") from and against any and all loss, damage, injury, liability, claim, demand, cost or expense (including, without limitation, attorney's, consultant's and expert's fees, and court costs), fine or penalty (collectively, "Loss") incurred by any person (including, without limitation, any Indemnified Party, Contractor, or any employee of Contractor or of any Indemnified Party) arising out of or in any manner connected with (i) any work performed by Contractor, or (ii) any act or omission of Contractor, its officers, agents or employees, or (iii) any breach of this agreement by Contractor.

B. The right to indemnity under this Section 8 shall accrue upon occurrence of the event giving rise to the Loss, and shall apply regardless of any negligence or strict liability of any Indemnified Party, except where the Loss is caused by the sole active negligence of an Indemnified Party as established by the final judgment of a court of competent jurisdiction. The sole active negligence of any Indemnified Party shall not bar the recovery of any other Indemnified Party.

C. Contractor expressly and specifically assumes potential liability under this Section 8 for claims or actions brought by Contractor's own employees. Contractor waives any immunity it may have under worker's compensation or industrial insurance acts to indemnify Railroad under this Section 8. Contractor acknowledges that this waiver was mutually negotiated by the parties hereto.

D. No court or jury findings in any employee's suit pursuant to any worker's compensation act or the Federal Employers' Liability Act against a party to this Agreement may be relied upon or used by Contractor in any attempt to assert liability against Railroad.

E. The provisions of this Section 8 shall survive the completion of any work performed by Contractor or the termination or expiration of this Agreement. In no event shall this Section 8 or any other provision of this Agreement be deemed to limit any liability Contractor may have to any Indemnified Party by statute or under common law.

Section 9. RESTORATION OF PROPERTY.

In the event Railroad authorizes Contractor to take down any fence of Railroad or in any manner move or disturb any of the other property of Railroad in connection with the work to be performed by Contractor, then in that event Contractor shall, as soon as possible and at Contractor's sole expense, restore such fence and other property to the same condition as the same were in before such fence was taken down or such other property was moved or disturbed. Contractor shall remove all of Contractor's tools, equipment, rubbish and other materials from Railroad's property promptly upon completion of the work, restoring Railroad's property to the same state and condition as when Contractor entered thereon.

Section 10. WAIVER OF DEFAULT.

Waiver by Railroad of any breach or default of any condition, covenant or agreement herein contained to be kept, observed and performed by Contractor shall in no way impair the right of Railroad to avail itself of any remedy for any subsequent breach or default.

Section 11. MODIFICATION - ENTIRE AGREEMENT.

No modification of this Agreement shall be effective unless made in writing and signed by Contractor and Railroad. This Agreement and the exhibits attached hereto and made a part hereof

constitute the entire understanding between Contractor and Railroad and cancel and supersede any prior negotiations, understandings or agreements, whether written or oral, with respect to the work to be performed by Contractor.

Section 12. ASSIGNMENT - SUBCONTRACTING.

Contractor shall not assign or subcontract this Agreement, or any interest therein, without the written consent of the Railroad. Contractor shall be responsible for the acts and omissions of all subcontractors, and shall require all subcontractors to maintain the insurance coverage required to be maintained by Contractor as provided in this Agreement, and to indemnify Contractor and Railroad to the same extent as Railroad is indemnified by Contractor under this Agreement.

EXHIBIT C

Union Pacific Railroad Company Insurance Provisions For Contractor's Right of Entry Agreement

Contractor shall, at its sole cost and expense, procure and maintain during the course of the Project and until all Project work on Railroad's property has been completed and the Contractor has removed all equipment and materials from the Railroad's property and has cleaned and restored Railroad's property to Railroad's satisfaction, the following insurance coverage:

A. Commercial General Liability insurance. Commercial general liability (CGL) with a limit of not less than \$2,000,000 each occurrence and an aggregate limit of not less than \$4,000,000. CGL insurance must be written on ISO occurrence form CG 00 01 12 04 (or a substitute form providing equivalent coverage).

The policy must also contain the following endorsement, which must be stated on the certificate of insurance:

- Contractual Liability Railroads ISO form CG 24 17 10 01 (or a substitute form providing equivalent coverage) showing "Union Pacific Railroad Company Property" as the Designated Job Site.

B. Business Automobile Coverage insurance. Business auto coverage written on ISO form CA 00 01 (or a substitute form providing equivalent liability coverage) with a combined single limit of not less than \$2,000,000 for each accident.

The policy must contain the following endorsements, which must be stated on the certificate of insurance:

- Coverage For Certain Operations In Connection With Railroads ISO form CA 20 70 10 01 (or substitute form providing equivalent coverage) showing "Union Pacific Property" as the Designated Job Site.
- Motor Carrier Act Endorsement – Hazardous materials clean up (MCS-90) if required by law.

C. Workers Compensation and Employers Liability insurance. Coverage must include but not be limited to:

- Contractor's statutory liability under the workers' compensation laws of the state(s) affected by this Agreement.
- Employers' Liability (Part B) with limits of at least \$500,000 each accident, \$500,000 disease policy limit \$500,000 each employee.

If Contractor is self-insured, evidence of state approval and excel workers compensation coverage must be provided. Coverage must include liability arising out of the U.S. Longshoremen's and Harbor Workers' Act, the Jones Act, and the Outer Continental Shelf Land Act, if applicable.

The policy must contain the following endorsement, which must be stated on the certificate of insurance:

- Alternate Employer endorsement ISO form WC 00 03 01 A (or a substitute form providing equivalent coverage) showing Railroad in the schedule as the alternate employer (or a substitute form providing equivalent coverage).

D. Railroad Protective Liability insurance. Contractor must maintain Railroad Protective Liability insurance written on ISO occurrence form CG 00 35 12 04 (or a substitute form providing equivalent coverage) on behalf of Railroad as named insured, with a limit of not less than \$2,000,000 per occurrence and an aggregate of \$6,000,000. A binder stating the policy is in place must be submitted to Railroad before the work may be commenced and until the original policy is forwarded to Railroad.

E. Umbrella or Excess insurance. If Contractor utilizes umbrella or excess policies, these policies must “follow form” and afford no less coverage than the primary policy.

F. Pollution Liability insurance. Pollution Liability coverage must be included when the scope of the work as defined in the Agreement includes installation, temporary storage, or disposal of any “hazardous” material that is injurious in or upon land, the atmosphere, or any watercourses; or may cause bodily injury at any time.

Pollution liability coverage must be written on ISO form Pollution Liability Coverage Form Designated Sites CG 00 39 12 04 (or a substitute form providing equivalent liability coverage), with limits of at least \$5,000,000 per occurrence and an aggregate limit of \$10,000,000.

If the scope of work as defined in this Agreement includes the disposal of any hazardous or non-hazardous materials from the job site, Contractor must furnish to Railroad evidence of pollution legal liability insurance maintained by the disposal site operator for losses arising from the insured facility accepting the materials, with coverage in minimum amounts of \$1,000,000 per loss, and an annual aggregate of \$2,000,000.

Other Requirements

G. All policy(ies) required above (except worker’s compensation and employers liability) must include Railroad as “Additional Insured” using ISO Additional Insured Endorsements CG 20 26, and CA 20 48 (or substitute forms providing equivalent coverage). The coverage provided to Railroad as additional insured shall, to the extent provided under ISO Additional Insured Endorsement CG 20 26, and CA 20 48 provide coverage for Railroad’s negligence whether sole or partial, active or passive, and shall not be limited by Contractor’s liability under the indemnity provisions of this Agreement.

H. Punitive damages exclusion, if any, must be deleted (and the deletion indicated on the certificate of insurance), unless the law governing this Agreement prohibits all punitive damages that might arise under this Agreement.

I. Contractor waives all rights of recovery, and its insurers also waive all rights of subrogation of damages against Railroad and its agents, officers, directors and employees. This waiver must be stated on the certificate of insurance.

J. Prior to commencing the work, Contractor shall furnish Railroad with a certificate(s) of insurance, executed by a duly authorized representative of each insurer, showing compliance with the insurance requirements in this Agreement.

K. All insurance policies must be written by a reputable insurance company acceptable to Railroad or with a current Best’s Insurance Guide Rating of A- and Class VII or better, and authorized to do business in the state(s) in which the work is to be performed.

L. The fact that insurance is obtained by Contractor or by Railroad on behalf of Contractor will not be deemed to release or diminish the liability of Contractor, including, without limitation, liability under the indemnity provisions of this Agreement. Damages recoverable by Railroad from Contractor or any third party will not be limited by the amount of the required insurance coverage.



Manager's Report

To: Board of Directors
From: David Goyer, General Manager
Date: June 20, 2024

RE: Item #3 – Addendum to the Development Agreement for the Construction of the A-Line pipeline.

The Board will review and consider executing the Addendum to the Development Agreement for the construction of the A-Line pipeline replacement and connection of the Lincoln Street Affordable Housing Sewer System.

Attachments for each item included.

Recommended Action:

A motion to approve and execute the Addendum to the Development Agreement for the construction of the A-Line pipeline replacement and connection of the Lincoln Street Affordable Housing Sewer System.

Roll call vote.

ADDENDUM TO DEVELOPMENT AGREEMENT
for
CONSTRUCTION OF THE A-LINE PIPELINE
REPLACEMENT AND CONNECTION OF THE LINCOLN STREET
AFFORDABLE HOUSING SEWER SYSTEM

This Addendum to Development Agreement for Construction of A-Line Pipeline Replacement and Connection of the Lincoln Street Affordable Housing Sewer System is made on June ____, 2024, between Lake Oroville Area Public Utility District, hereinafter referred to as “District” and RICHMAN OROVILLE APARTMENTS, LP, a Delaware limited partnership, hereinafter referred to as “Developer”.

WHEREAS, Section 1 of the Development Agreement provides: “A-Line Replacement and this Agreement are conditioned on Union Pacific Railroad consent to the work.”

WHEREAS, the Union Pacific Railroad (Railroad) has conditioned its consent to the Project work on the terms set forth in a Supplemental Agreement for License to be made between District and Railroad (Supplemental Agreement). A copy of the Supplemental Agreement is attached as Exhibit 1.

District agrees to execute the Supplemental Agreement to facilitate Developer’s completion of the Pipeline Replacement Project, on the terms set forth below:

1. Developer shall require and ensure that Contractor execute the Contractor Right of Entry Agreement as provided in Article 3 of the Supplemental Agreement. A copy of the Right of Entry Agreement is attached as Exhibit “2”.
2. Developer shall require and ensure that Contractor comply the terms and conditions of the Supplemental Agreement, including those set forth in its Exhibits “A”, “B”, and “C”, at no expense to District.
3. Developer shall require and ensure that Contractor provide notice of commencement of work to Railroad, that it coordinates work with Railroad, and that it prosecutes the work diligently to completion as provided in Article 4 of the Supplemental Agreement.
4. Developer shall require and ensure that Contractor provide notice of commencement of work to Railroad’s Lessee and that it pays damages as provided in Article 8 of the Supplemental Agreement.
5. Developer shall pay administrative fees in the amount of \$3,500 as provided in Article 7 of the Supplemental Agreement.
6. Developer shall comply, or it shall ensure that Contractor complies, with all other terms and conditions of the Supplemental Agreement.

7. Notwithstanding the recitals to the Right of Entry Agreement, Developer acknowledges and agrees that Contractor was hired by Developer and that Developer – not District – is responsible for the breaches, errors, acts and omissions of Contractor.
8. Developer shall defend and indemnify District against claims arising out of or relating to (1) the Supplemental Agreement; (2) the Right of Entry Agreement; or (3) the breaches, errors, acts, or omissions of Developer, Contractor, or persons for whom either is legally responsible.
9. Except as expressly provided above, the terms of the Development Agreement shall remain in full force and effect.

**LAKE OROVILLE AREA PUBLIC
UTILITY DISTRICT**

By: _____
_____, President

ATTEST:

By: _____
_____, General Manager

DEVELOPER/DEVELOPER/OWNER:

RICHMAN OROVILLE APARTMENTS, LP,
a Delaware limited partnership

By: _____
EDWARD S. MAYER, President

RICHMAN OROVILLE GP, LLC, a Delaware
Limited Liability Company

By: _____
_____, Its Administrative
General Partner

**RICHMAN GROUP OF CALIFORNIA
DEVELOPMENT COMPANY, LLC,** a
California Limited Liability Company,
Co-General Partner

By: _____
RICK WESTBERG, Executive Vice-President
**BUTTE COUNTY AFFORDABLE HOUSING
DEVELOPMENT CORPORATION**, a California
Non-Profit Public Benefit Corporation

By: _____
_____, Managing Partner

TRG OROVILLE MEMBER, LLC, a
Delaware Limited Liability Company

By: _____
RICK WESTBERG, Executive Vice-President



Manager's Report

To: Board of Directors

From: David Goyer, General Manager

Date: June 20, 2024

RE: Item #4 – Appointment of SC-OR Commissioners for 2024-2025

In June of each year, the District Board President is to appoint two (2) Directors to represent the District on the SC-OR Commission. Directors Mastelotto and Salvucci are the 2023-2024 SC-OR Commissioners and Director Mastelotto is the designated voting member.

Recommended Action: President Marciniak will appoint two Directors to represent the District as 2024-2025 SC-OR Commissioners and designate one as a voting member.